

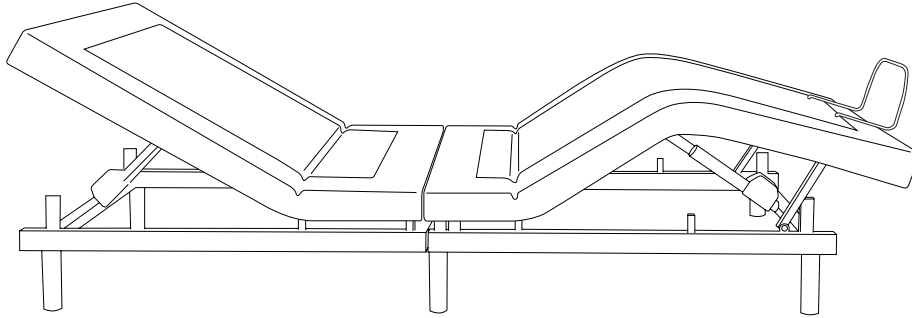

MotionComfort

Warranty Card



CONGRATULATIONS ON THE PURCHASE OF YOUR NEW MOTIONCOMFORT ADJUSTABLE BASE.

TO FACILITATE ANY FUTURE CUSTOMER SERVICE ENQUIRIES, PLEASE KEEP A COPY OF THIS GUIDE AND THE SALES RECEIPT FROM YOUR MOTIONCOMFORT DEALER.

We recommend your MotionComfort adjustable base is purchased with a compatible and recommended mattress for ideal performance and durability. The use of your MotionComfort adjustable base with a non-compatible mattress may cause stress on both the mattress and base and void the warranties of both.

Because we stand behind the quality design and craftsmanship of our products, The Comfort Group is proud to offer you, the original purchaser, the following product warranty against manufacturing defects in workmanship and materials.

YOUR WARRANTY

2 YEAR ELECTRICAL GUARANTEE

Your MotionComfort base has a full two year guarantee against defects in materials and workmanship on all electrical/mechanical parts of the base. We will either repair, or replace, at no cost to the original purchaser, any defective part.

10 YEAR STRUCTURAL GUARANTEE

Your MotionComfort base has a full 10 year guarantee against defects in materials and workmanship on all structural parts of the base. We will either repair, or replace, at no cost to the original purchaser, any defective structural component of the base. Structural components include the frame and legs.

This warranty does not extend to normal wear and tear, or damage caused by abuse, misuse, or negligence. During this period, if The Comfort Group is satisfied that material or workmanship is faulty, it will repair or replace your MotionComfort adjustable base at its discretion. This warranty applies from the date of purchase. The warranty does not cover failure of components if the bed is subjected to a load greater than stipulated in the User's Manual, or damage caused by misuse. Any mattress purchased in conjunction with the MotionComfort adjustable base is supplied with its own warranty and as such is not covered by this warranty.

TERMS AND CONDITIONS

This warranty is offered against faulty workmanship and or faulty materials commencing on the date of purchase.

- This warranty does not extend to normal wear and tear or damage caused by abuse, misuse, negligence, transportation or the failure to comply with the care and maintenance instructions.
- Small manufacturing irregularities that do not affect the performance of the bed are specifically excluded from this warranty.
- Comfort issues relating to customers' preferences are specifically excluded from the warranty.
- Making an incorrect buying decision does not constitute a manufacturing fault.

- In some cases, inspection by a company representative or its agent at the location of the item may be necessary. This may take time for geographical reasons.
- Any item returned to The Comfort Group for repair that is deemed to not have a manufacturing fault, or is outside of the warranty period, will attract a repair cost and transport charges, regardless of the age of the item.
- During the warranty period, if The Comfort Group is satisfied that workmanship or materials are faulty, it will repair or replace the product at its discretion.
- The warranty period will not be extended or altered as a result of a repair or replacement under the terms of this warranty or otherwise.
- The Comfort Group reserves the right to substitute a material of equal or greater quality on the particular item being repaired or replaced if identical materials or items are not available at the time of repair or replacement.
- This warranty is solely given to, and for the benefit of, the original purchaser of the product who purchased the product from an Authorised Reseller of MotionComfort adjustable bases. Proof of purchase will be required.
- This warranty begins on the date of purchase for new unused units, and the date of manufacture for units that have been used as floor or display models.
- **WORKING WEIGHT LIMITS:** This product is not rated to support weights in excess of 355kg for Queen size or 150kg for Long Single and King Single bases including the weight of the mattress. Exceeding this weight restriction could damage the bed and/or cause injury and will void the warranty.
- This warranty is only valid in Australia and New Zealand.

Parts include the following

- Head/foot motor
- Power cord, power supply and input cord
- Mounting bracket
- Control box
- Support struts
- Remote control

(For Australian Consumers Only)

Subject to the Australian Consumer Law, repair or replacement under this warranty shall be the sole remedy of the purchaser and there shall be no liability on The Comfort Group for any special indirect, incidental, or consequential damages or for any other damage, claim, or loss not expressly covered by the terms of this warranty. This limited warranty does not include reimbursement for inconvenience, removal, installation, set up time, loss of use, shipping, or any other costs or expense. The Comfort Group makes no other warranty whatsoever, express or implied, and all implied warranties of merchantability and fitness for a particular purpose are disclaimed by The Comfort Group and excluded from this agreement to the extent permitted by law.

THIS WARRANTY DOES NOT COVER THE FOLLOWING EVENTUALITIES

- This warranty does not include reimbursement for inconvenience, removal, part(s), installation, bed setup, loss of use, shipping or any other costs or expenses not expressly covered in this warranty.
- Damage resulting from misuse or abuse by the purchaser.
- Damage caused by repairs or parts replacement by an unauthorised person.
- Damage caused if the adjustable base has been mishandled (including during shipping), subject to physical abuse or an improper power source, or damage while adhering to the Owner's Manual and this warranty.
- Damaged mattresses, bedding, cables, electrical cords or accessories supplied by dealers.
- Modifications of the adjustable base without prior written consent by The Comfort Group.
- Costs for unauthorised service calls for the purpose of educating the purchaser about the adjustable base or locating proper functioning power outlets.
- If the recommended weight restrictions are exceeded.
- If used in any environment or commercial setting which is not intended or generally used by the public for an adjustable base.
- Damage to foam shroud by improper handling or misuse.

Australian Comfort Group Pty Ltd
447 Foleys Road, Deer Park, Melbourne, VIC
3023

ABN: 23 098 742 584

Phone: 1800 633 358

New Zealand Comfort Group Ltd

41-71 Great South Road, Otahuhu, Auckland,
1061

Phone: 0800 753 377